



Indexing Hopper Scale

The triple indexing hopper scale fits many applications for the processor. The hopper scale with conveyor automatically fills the box below the chute. Once full, the filled box is automatically released and a new empty box is indexed under the hopper for uninterrupted filling. The hopper scale keeps a total for all boxes. Applications include front halves and whole wogs. The indexing scale is perfect for plants needing an accurate record when shipping raw materials inter-company. Totally automatic operation generates significant labor savings.

Features:

- MicroWeigh indicator
- Stainless steel construction
- Compact design -minimal floor space needed
- Fills 15-20 boxes a minute

Advantages:

- Labor savings
- Proven performance
- Low maintenance
- Accuracy

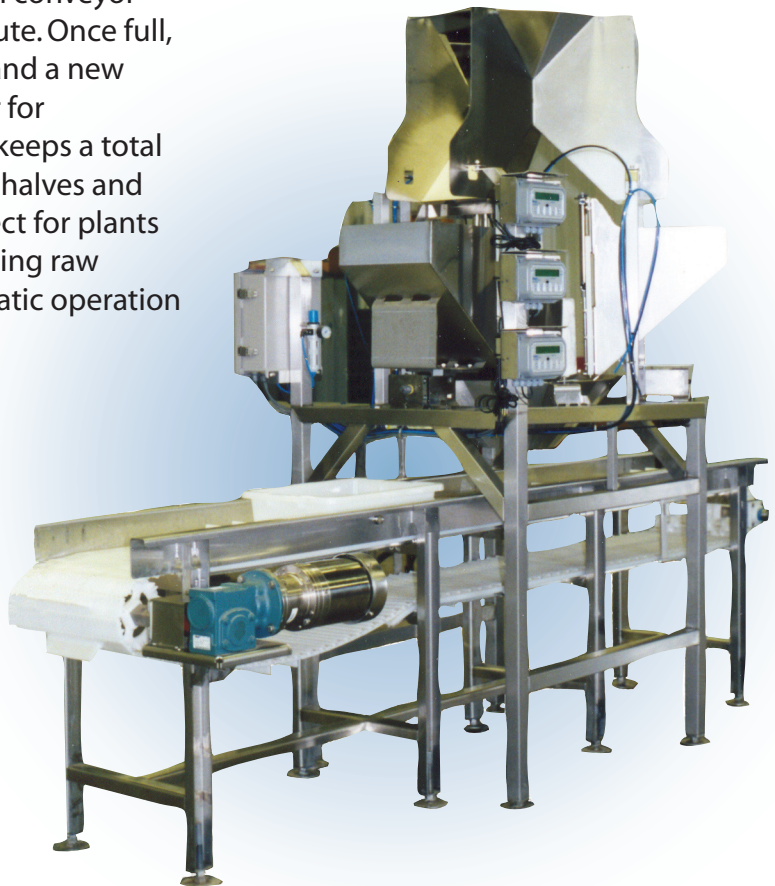

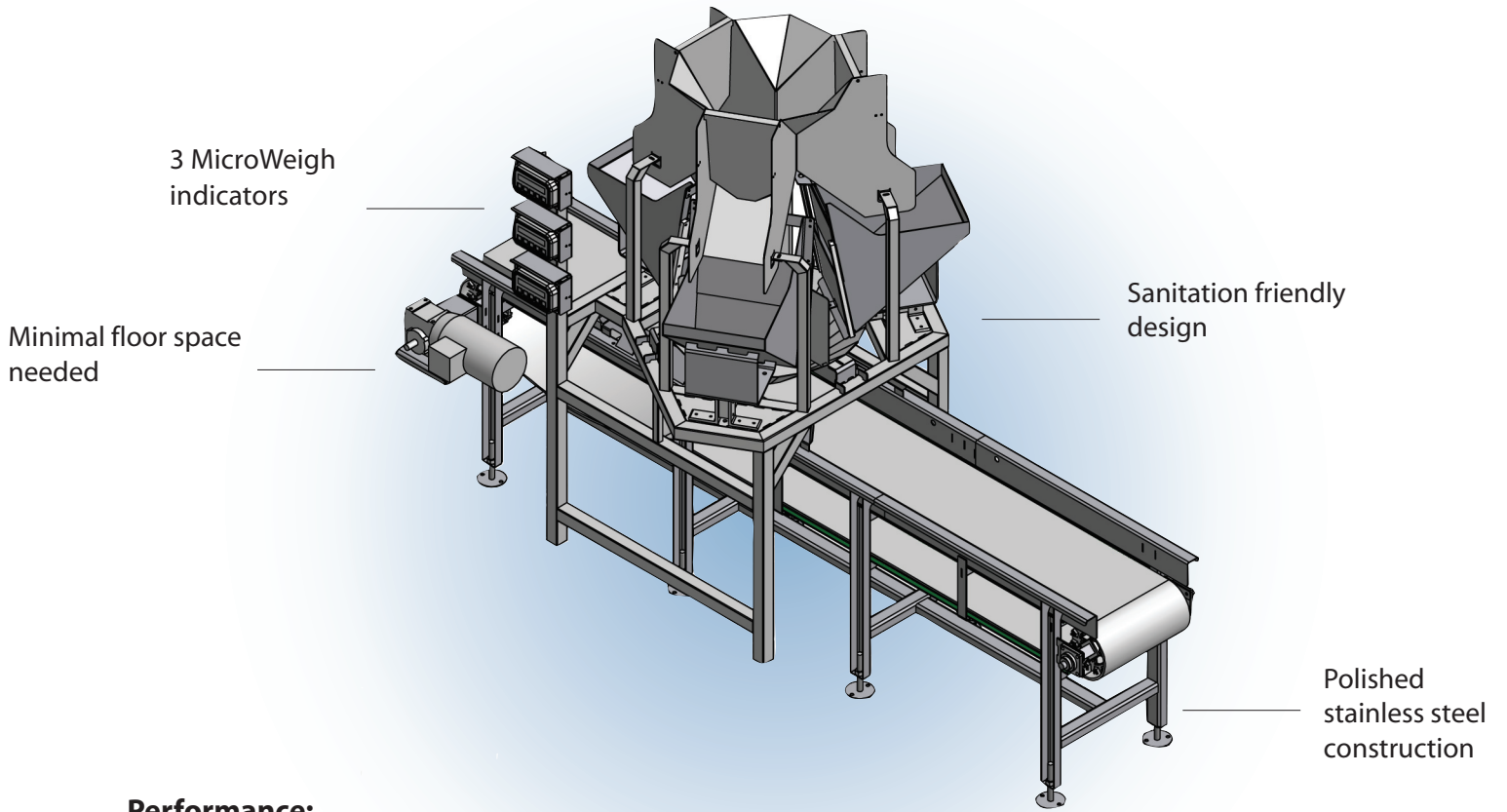

Performance:

Accuracy: +/- 0.1 lb.
 Speed: 15 to 20 boxes per minute
 Washdown: IP69 K /NEMA 4

Physical:

Capacity:	50 lbs.	Triple Indexer
	50 or 75 lbs.	Dual Indexer (can be upgraded to triple)
	50, 75 or 100 lbs.	Single Indexer

Options available

Dual Indexer

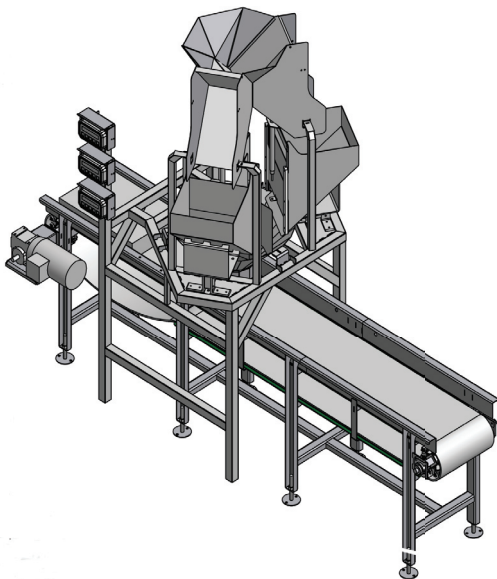

Single Indexer with knuckle chain belt

